

CONFIDENTIAL

THIS DOCUMENT IS THE SOLE PROPERTY OF THOREN CAGING SYSTEMS, INC. AND IS LOANED UPON CONDITION THAT IT IS NOT TO BE REPRODUCED, COPIED OR LOANED IN WHOLE OR IN PART OR USED FOR FURNISHING INFORMATION TO OTHERS OR FOR ANY OTHER PURPOSE DETRIMENTAL TO THE INTEREST OF THOREN CAGING SYSTEMS, INC. AND SHALL BE RETURNED OR DESTROYED UPON REQUEST. NO PART OF THIS DOCUMENT MAY BE DISCLOSED TO ANY UNAUTHORIZED PARTY FOR ANY PURPOSE WITHOUT EXPRESS WRITTEN PERMISSION FROM THOREN CAGING SYSTEMS, INC.

**MAXI-MISER MOBILE SYSTEM
MODEL #6-30-6-5-1-4-5TM
MOBILE FULL RACK
TOP MOUNT BLOWER BOXES**

GENERAL NOTES:

1. THE AIR SUPPLY AND EXHAUST SETUPS MAY VARY DEPENDING ON CUSTOMER REQUIREMENTS.
2. ITEMS IN SOME VIEWS HAVE BEEN OMITTED FOR CLARITY.

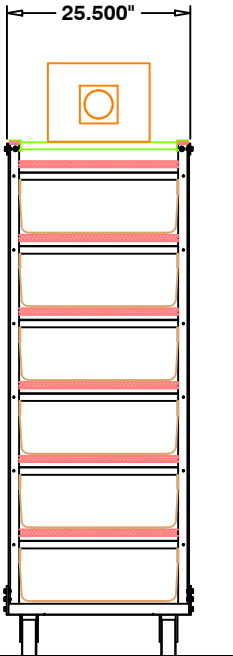
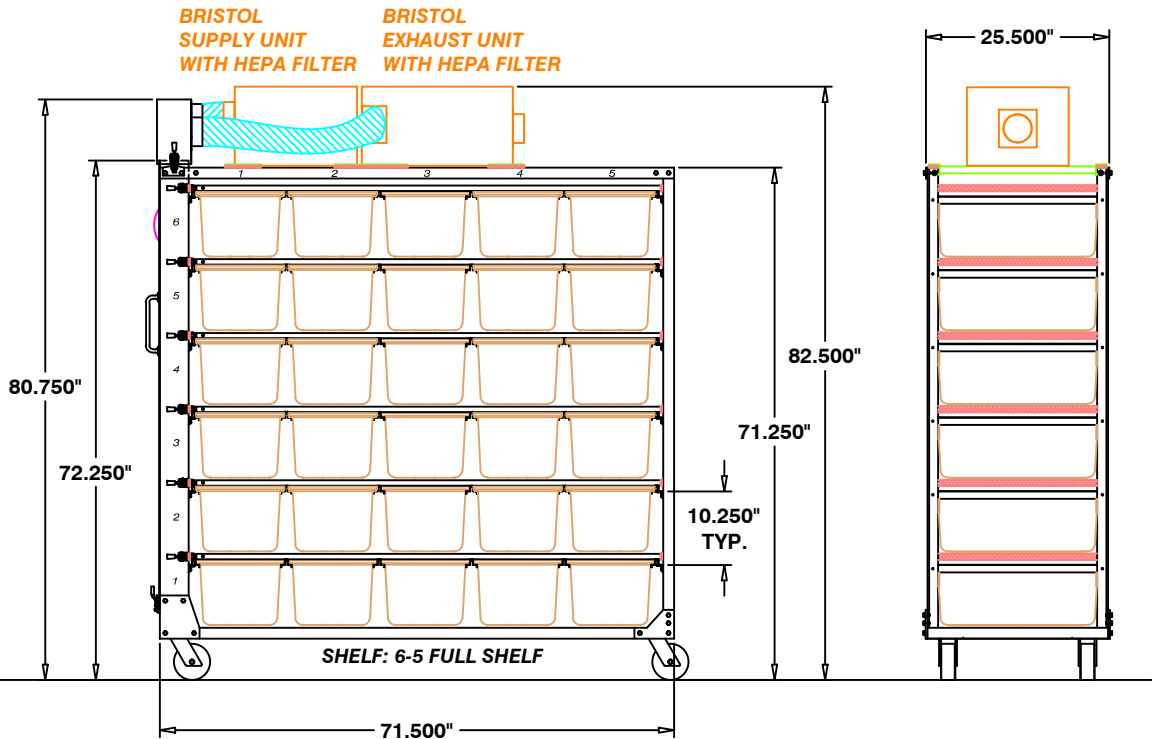
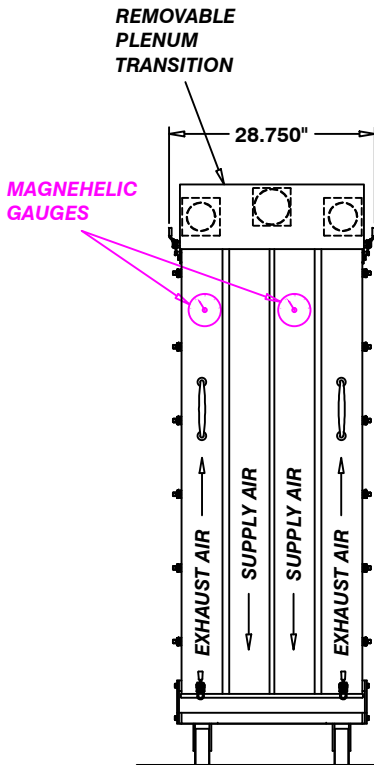
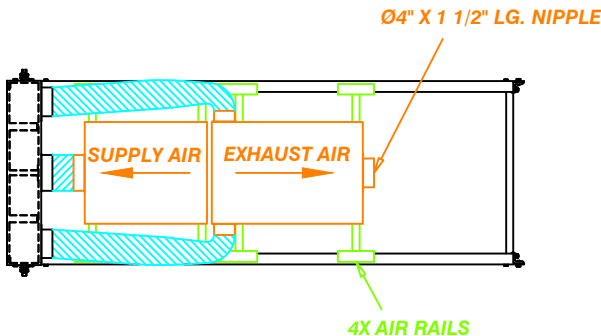

AVAILABLE CAGES THAT
WILL FIT THIS RACK



#6 CAGE (LARGE RAT CAGE)
DIM: 12.125" X 23.375" X 9.000"

THOREN CAGING SYSTEMS INC.
815 WEST SEVENTH STREET
HAZLETON, PENNSYLVANIA 18201

MAXI-MISER MOBILE SYSTEM
MODEL #6-30-6-5-1-4-5TM
MOBILE FULL RACK
TOP MOUNT BLOWER BOXES

DRAWN BY: HLH
CHECKED BY:

SCALE: 3/32"=1" (D)
DATE: 8-1-17

DWG NO:
6-30-6-5-1-4-5TM